

STEP 2: REMOVE PULL CONTROL VALVE MOUNTING BOLTS MARKED "B"

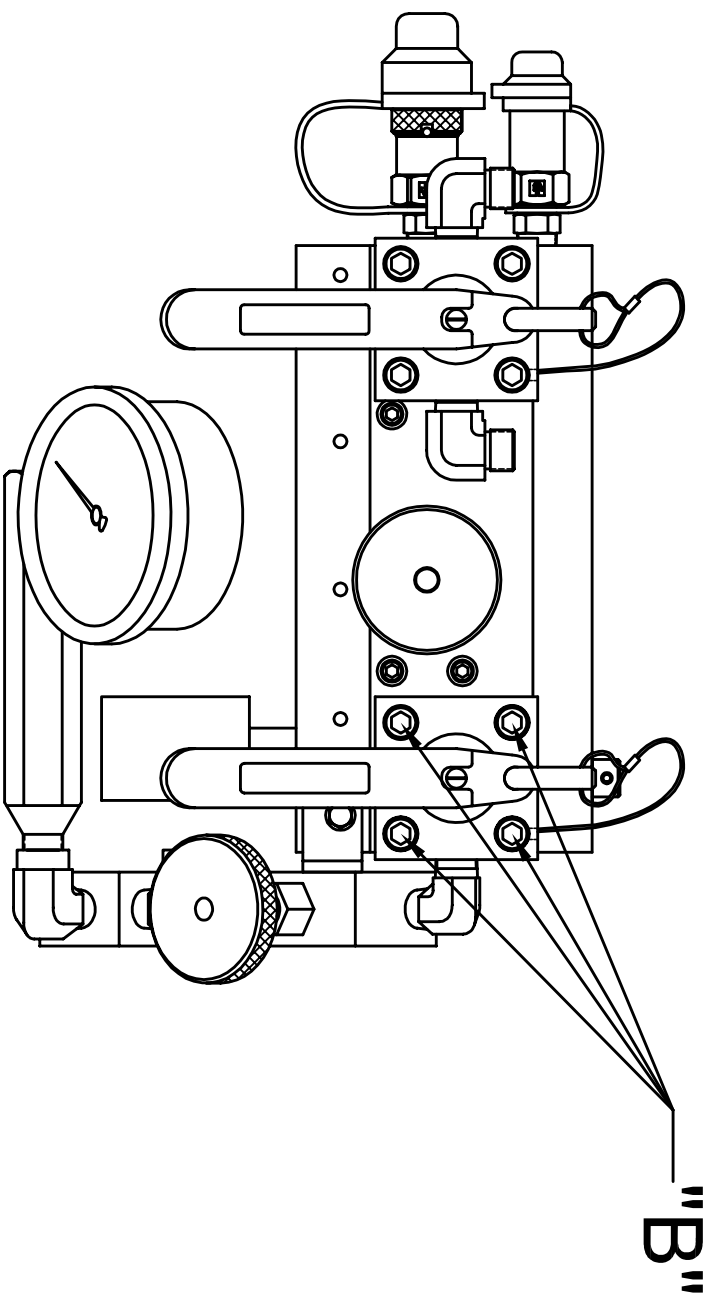

STEP 3: ROTATE PULL CONTROL VALVE ASSEMBLY TO EXPOSE LOWER VALVE BLOCK MOUNTING SCREWS "C".

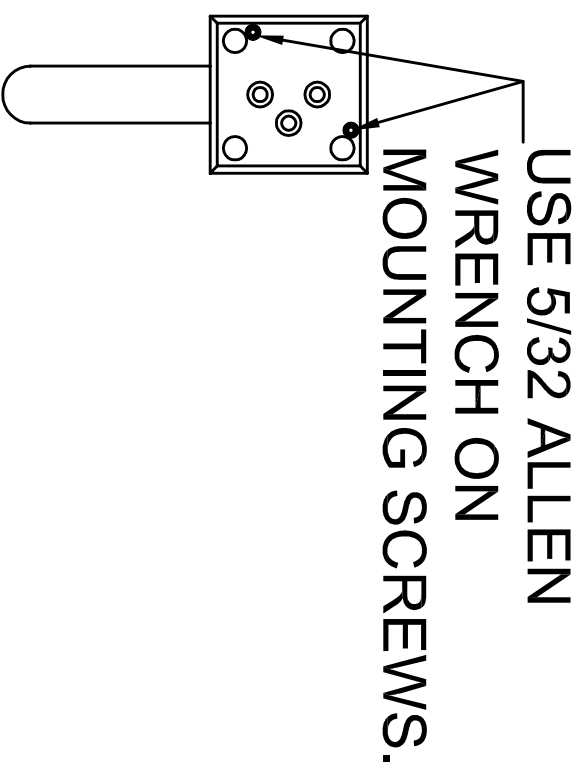
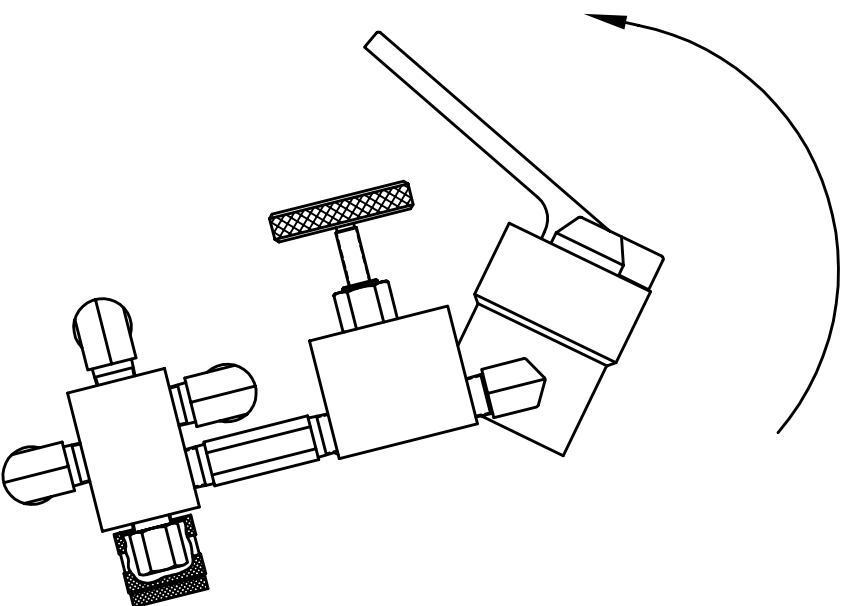

STEP 4: SEPARATE UPPER AND LOWER HALF OF VALVE ASSEMBLY. TURN VALVE ROTOR HEX WHERE HANDLE MOUNTS TO ROTATE THE 5 HOLE PATTERN ON THE ROTOR FACE SO THE EXTRA HOLE IS AWAY FROM HANDLE SHOULD BE. NOTE THE POSITON OF SMALL MOUNTING HOLES "D" TO HANDLE AND ROTOR.

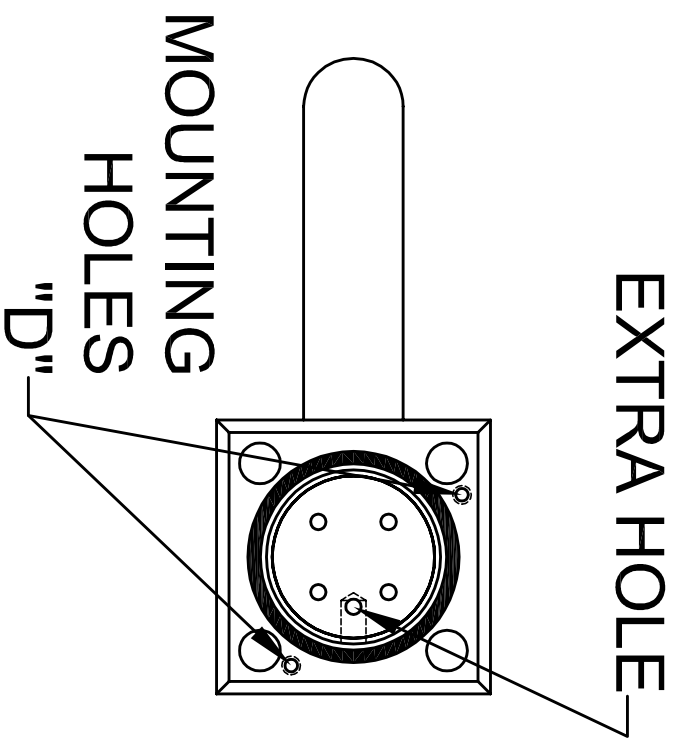
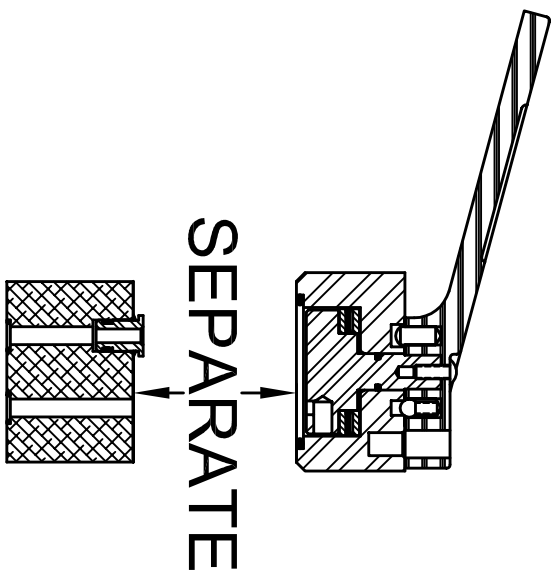

**STEP 5: REASSEMBLE VALVE ASSEMBLY
AND INTENSIFIER SHROUD IN THE
REVERSE ORDER OF STEPS 4 THROUGH 1.**